



# Installation, Operation, and Maintenance Manual

**IM 1365**

Group: Controls

Part Number: IM 1365

Date: June 2024

## MT6210 A2L Leak Mitigation Control

Packaged Rooftop and Water Source Heat Pump Systems

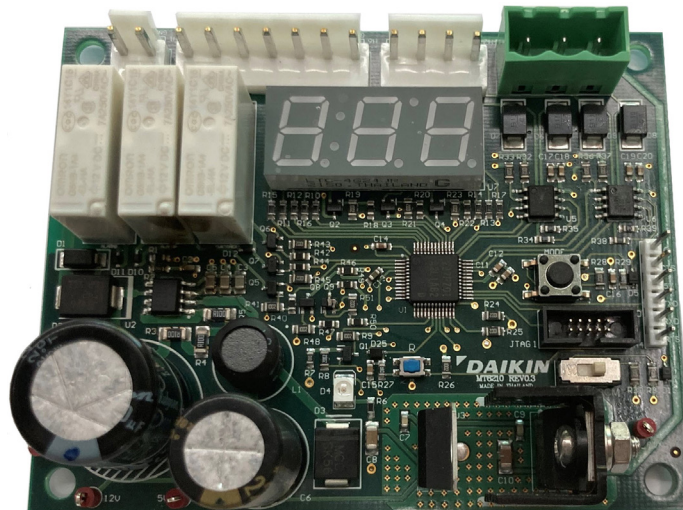

# Table of Contents

<b>Introduction</b> . . . . .	<b>3</b>
Approved Refrigerant Detection System . . . . .	4
Functionality . . . . .	5
<b>Connections</b> . . . . .	<b>6</b>
User Interface Functions . . . . .	7
System Diagram . . . . .	7
<b>Sequence of Operation</b> . . . . .	<b>8</b>
Power-Up . . . . .	8
Run . . . . .	8
Alarm - Active Refrigerant Leak Detected . . . . .	8
Fault - Abnormal System Operation . . . . .	9
<b>Display Modes</b> . . . . .	<b>10</b>
<b>Replacing Faulty Sensors</b> . . . . .	<b>15</b>
<b>MT6210 Firmware Updating Procedure</b> . . . . .	<b>17</b>
<b>Hardware Specifications</b> . . . . .	<b>19</b>

© 2024 Daikin Applied Americas Inc. d/b/a Daikin Applied, Minneapolis, MN. All rights reserved throughout the world. Daikin Applied reserves the right to change any information contained herein without prior notice. This document contains the most current product information as of this printing. For the most up-to-date product information, please go to [www.DaikinApplied.com](http://www.DaikinApplied.com).  
™<sup>®</sup> Rebel, SmartSource, MicroTech, and Daikin Applied are trademarks or registered trademarks of Daikin Applied Americas Inc. The following are trademarks or registered trademarks of their respective companies: BACnet from American Society of Heating, Refrigerating and Air-Conditioning Engineers, Inc.; Modbus from Schneider Electric; and Windows from Microsoft Corporation.

# Introduction

Daikin Applied units equipped with compressors utilizing an A2L refrigerant, such as R32, require means for mitigation in the unlikely event of a refrigerant leak. The mitigation means is prescribed in UL 60335-2-40 to ensure there is never a build-up of leaked refrigerant in excess of the lower flammability limit (LFL) which may result in a combustion event in the unit. The primary mitigation actions include providing circulating airflow adequate to dilute the leaked refrigerant and to suppress the activation of potential ignition sources, such as contactors and heating elements. The effectiveness of an implemented mitigation strategy is rigorously tested at a certified UL test laboratory to ensure the effectiveness of the detection and mitigating action for each product prior to release for sale.

This manual is intended for technicians or other qualified personnel. Contact the Daikin Applied Controls Customer Support group at 866-462-7829 or email [DaikinControls@daikinapplied.com](mailto:DaikinControls@daikinapplied.com) for additional assistance.

## Reference Documents

Title	Number	Company	Source
A Data Communication Protocol for Building Automation and Control Networks	ANSI/ASHRAE	American Society of Heating, Refrigerating, and Air Conditioning Engineers	<a href="http://www.ashrae.org">www.ashrae.org</a>
MicroTech Unit Controller for Rebel Commercial Rooftop Systems	OM 1141	Daikin Applied	<a href="http://www.DaikinApplied.com">www.DaikinApplied.com</a>
MicroTech SmartSource (MT2300) WSHP Unit Controller Operation Manual	OM 1364		
MicroTech Rebel Rooftop Network Protocol Information Manual	ED 15112		
MicroTech SmartSource WSHP Network Protocol Information Manual	ED 19129		

## Hazardous Information Messages

** DANGER**

Danger indicates a hazardous situation, which will result in death or serious injury if not avoided.

** WARNING**

Warning indicates a potentially hazardous situations, which can result in property damage, personal injury, or death if not avoided.

** CAUTION**

Caution indicates a potentially hazardous situations, which can result in minor injury or equipment damage if not avoided.

**NOTICE**

Notice indicates practices not related to physical injury.

## Approved Refrigerant Detection System

Daikin Applied equipment equipped with an A2L refrigerant have a factory installed leak detection system. This UL-approved A2L refrigerant detection system (RDS) consists of the following components:

- A2L Leak Detection Control Board
  - Control Designation: MT6210
  - Daikin Applied Part Number: 910419225
  - Quantity: 1 controller per unit (typical)
- Refrigerant Sensor(s)
  - Daikin Applied Part Number: 910419801
  - Quantity: 1 to 8 sensors per unit

The sensor(s), if more than one, are wired in a daisy chain configuration and terminated at the mitigation board. The refrigerant sensors detect the presence of the A2L refrigerant outside of the sealed refrigeration piping and communicates the concentration levels directly to the MT6210. The MT6210 board communicates the refrigerant detection system status to the unit controller and other system components to initiate the appropriate mitigation response.

The factory installed RDS in the Daikin Applied equipment may not be field modified.

**⚠ WARNING**  
Field replacement components must be Daikin Applied approved service parts. The use of non-certified parts can result in property damage, personal injury, or death.

**⚠ WARNING**  
Do not attempt to disable or modify installed sensors in any way. Disabled or modified sensors can result in property damage, personal injury, or death.

**⚠ WARNING**  
The location of the refrigerant sensors must not be changed. Improperly located sensors can result in property damage, personal injury, or death.

**⚠ WARNING**  
Sensors must be properly mounted and secured to the original mounting brackets supplied with the unit. Improperly mounted sensors can result in property damage, personal injury, or death.

**⚠ WARNING**  
Do not allow the sensor inlet to become blocked. Sensors with blocked inlets can result in property damage, personal injury, or death.

**⚠ WARNING**  
Care should be taken when servicing the equipment to protect the refrigerant sensors from contamination, i.e. cleaning solutions, oil, lubricants, etc.

**⚠ WARNING**  
Care should be taken when servicing the equipment to protect the refrigerant sensors from physical damage, i.e. impact from hand tools.

**⚠ WARNING**  
Faulty sensors must be replaced promptly upon failure detection. Allowing the system to operate with faulty sensors can result in property damage, personal injury, or death.

## Functionality

The MT6210 A2L leak detection control is an accessory control that allows Daikin Applied equipment to meet the requirements defined in UL 60335-2-40 for units utilizing A2L refrigerants. The purpose of the MT6210 control is to activate the appropriate mitigation actions either directly using relay logic, indirectly by communicating to the unit controller, or a combination of both methods. The mitigation actions are defined by the specific appliance in which the controller is installed, and the following inputs/outputs are available:

1. Modbus “Client” serial communications with up to eight (8) approved refrigerant leak detection sensors.
2. 5VDC power supply for up to 300mA combined load on any one sensor or sensor network.
3. Modbus “Server” serial communications with a compatible unit controller.
4. 2 each binary outputs (5VDC) to communicate system events:
  - One for leak events (Alarm)
  - One for system errors, i.e. loss of sensor communications (Fault)
5. 2 each relay outputs (dry contacts):
  - One set of normally open contacts for mitigation activation (redundant contacts).
  - One set of normally open contacts for building owner notification.
6. Relay logic is summarized in [Table 6 on page 9](#).

# Connections

Figure 1: Board Layout

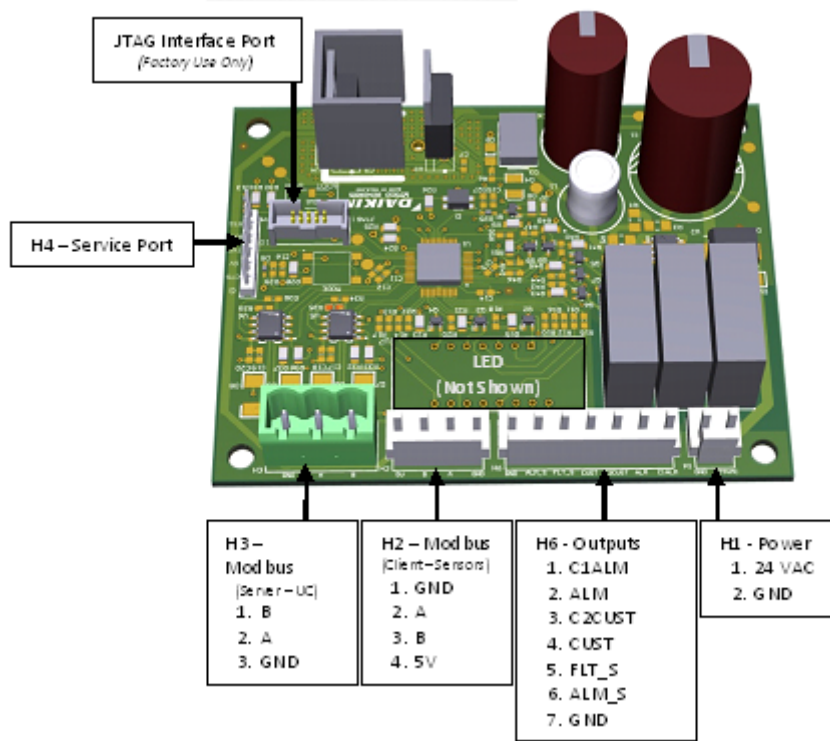

Table 1: MT6210 Connections

Connector	Pin	Label	Description
H1 Power	1	24 VAC	24 VAC Control Power from Transformer
	2	GND	Common / Chassis ground
H2 Modbus Client	1	GND	Common - Sensor Power
	2	A	Modbus Communications to Refrigerant Sensors
	3	B	Modbus Communications to Refrigerant Sensors
	4	5V	5VDC - Sensor Power
H3 Modbus Server	1	B	Modbus Communications to Unit Controller
	2	A	Modbus Communications to Unit Controller
	3	GND	Common
H4	1-6	Various	Service Port - for programming using the appropriate USB interface cable
JTAG1	1-10	None	Factory Use Only
H6 Outputs	1	C1ALM	Alarm Dry Contacts – Activates for Alarm or Fault
	2	ALM	
	3	C2CUST	Customer Dry Contacts – Activates for Alarm or Fault
	4	CUST	
	5	FLT_S	Fault Digital Output - System fault
	6	ALM_S	Alarm Digital Output - Leak Event
	7	GND	Common / Chassis ground

# User Interface Functions

## Mode Button

The Mode button is used to select user functions available on the LED display (See Display Modes on page 10).

## Reset Button

The Reset button forces the microprocessor into a hardware reset, interrupting normal operations. This button is used only during the programming process (See MT6210 Firmware Updating Procedure on page 17).

## Input Switch

Selects either “Single Chip Mode” (SCM) or “Boot Mode” (BOOT). SCM is for normal operation, BOOT is used during the programming process (See MT6210 Firmware Updating Procedure on page 17).

# System Diagram

Figure 2: System Diagram

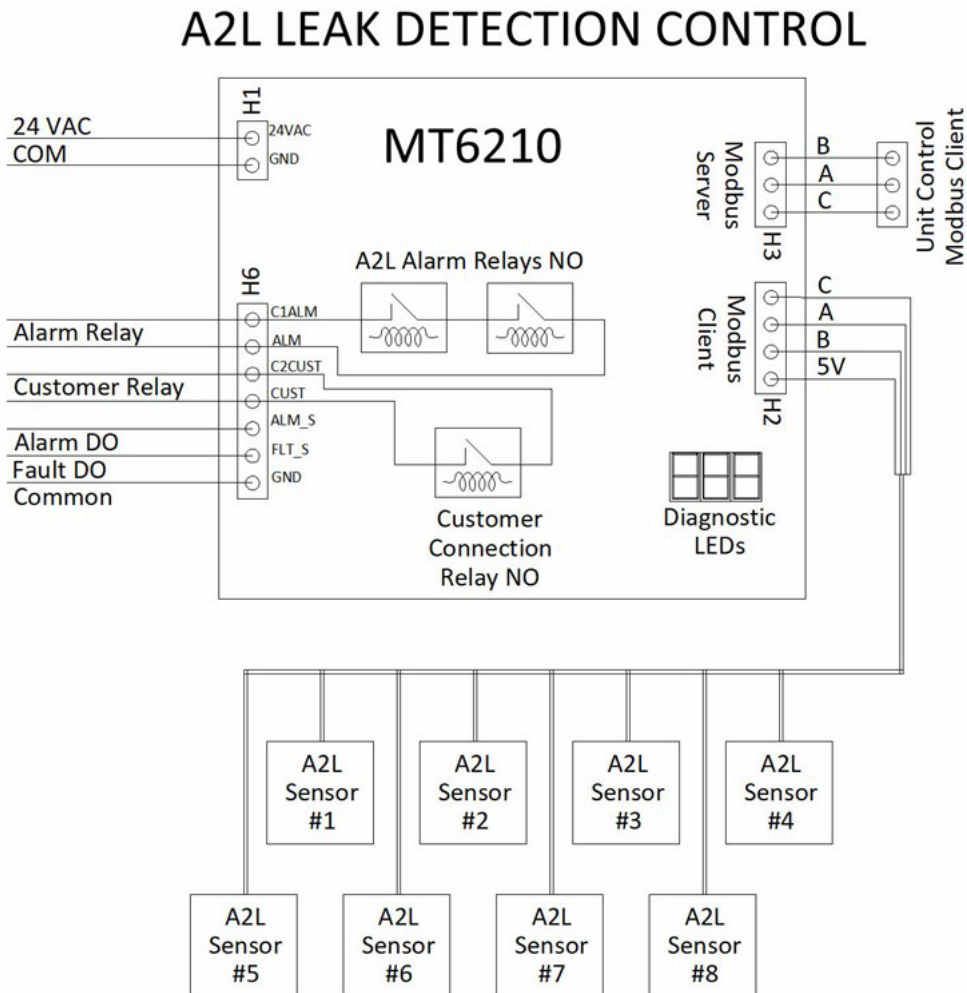

# Sequence of Operation

## Power-Up

At power-up, the MT6210 initiates the microprocessor and then begins establishing the two Modbus communication networks. This process involves the following activities:

- **Sensor discovery:**  
The control sends requests on the Modbus client network to sensors 1 through 8 to identify the number and addresses of all sensors available on the network.
- **Unit controller requests:**  
The control listens on the Modbus server network for communications from a unit controller (if present). Unit controller communications are not necessary for operation.
- **If the unit controller is present and communicating,** the number of required sensors for the system is sent to the MT6210, which stores this parameter. Otherwise, the MT6210 will use the default number of sensors programmed into its memory.

The power-up process takes approximately 30 seconds to complete, after which time the control will display the network summary as shown in [Table 2](#).

**Table 2: Power-Up Display**

LED Display	LED Display Interpretation	Description	Range
St UP	System Start-Up	30 second power-up sequence: initiates the two Modbus networks, allows time for sensor warm-up	N/A
NS =N	Number of Sensors	Indicates the expected number of A2L sensors (N) for the application	1 ... 8
S1 =1 or 0	Sensor #1 Status	Indicates Modbus communication with A2L sensor #1	0=None 1=Present
SN =1 or 0	Sensor #N Status	Indicates Modbus communication with A2L sensor #N (N = 2...8) (Status is shown for all 8 sensors)	0=None 1=Present
UC =1 or 0	Unit Control Modbus Status	Indicates Modbus communication with the unit controller	0=None 1=Present

## Run

Once the power-up sequence is complete, the MT6210 enters a normal run state. During the run state, the control monitors the Modbus networks and maintains the digital and binary outputs while executing the following specific activities:

1. Verifies that the number of discovered sensors matches the expected number for the specific system in which installed.
2. Verifies the addresses for all sensors are sequential, starting with "S01" and proceeding to "SN", where "N" is the expected number of sensors, e.g. if N=3 for the system, then discovered sensors would be "S01", "S02", and "S03".
3. Monitors the status of each individual refrigerant sensors, including the sensor status and %LFL detection level.
4. Monitors any requests from the unit controller (if present on the server Modbus network) and responds with the information requested.
5. Displays system status via the three seven-segment LEDs mounted on the board.

**Table 3: Run Indication**

Display	Indication
run	Normal Operation (No Alarms, No Faults)

6. Responds to any button presses detected on the MODE button.

## Alarm - Active Refrigerant Leak Detected

The MT6210 continuously monitors each refrigerant sensor's reported %LFL level via the client Modbus network. If any sensor reports a %LFL level above 15%, a refrigerant leak condition exists, and the control enters an "Alarm" condition.

The control executes the following actions when a leak event has been detected:

1. The Alarm relays are de-energized opening the Alarm relay contacts.
2. The Customer relay is energized closing the Customer relay contacts.
3. The Alarm binary output changes state from 5VDC (normal) to 0VDC (Alarm).
4. The Modbus state parameter is changed to indicate an alarm condition that will be reported to a unit controller requesting this information.
5. The diagnostic LEDs display the Alarm condition as shown in [Table 4](#).



**Table 4: Alarm Indications**

Display	Indication
A0N	Alarm - Sensor #N
LFL	Lower Flammability Limit
251	LFL % - Sensor #N (xx.x)

- The control continues to monitor the sensors in the network and maintains the alarm condition until all sensors are indicating less than 15% LFL.
- Once all LFL levels fall below 15%, the control maintains the alarm condition for an additional 5 minutes. During this 5-minute period, the display will indicate a timer countdown as shown in [Table 5](#).

**Table 5: Alarm/Timer Indications**

Display	Indication
A0N	Alarm - Sensor #N
LFL	Lower Flammability Limit
010	LFL % - Sensor #N (xx.x)
300	5-minute timer (seconds)

- Once the 5-minute timer has expired and all LFL remain below 15%, the control returns to a normal RUN mode, de-energizing all relays and digital outputs and setting the Modbus state parameter back to normal.

## Fault - Abnormal System Operation

The MT6210 continuously monitors the refrigerant detection system to ensure all elements of the system are operating properly. If any abnormality other than a leak detection, the control enters a Fault condition. A Fault condition can be caused by a number of system issues:

- Sensor Configuration: CfG**  
 A mismatch between the expected number of sensors and the actual number of communicating sensors.
- Loss of Communications: LOC**  
 Modbus failure with a discovered sensor.
- Sensor Self-Test Error: FLT**  
 A sensor has reported a self-test error. Each sensor runs internal diagnostics to verify the calibration and proper functioning of the sensing element, and reports that status of this self-test over the Modbus network to the MT6210.

If any of these fault conditions are detected, the control enters a "Fault" condition. The control executes the following actions when a fault event has been detected:

- The Fault binary output changes state from 5VDC (normal) to 0VDC (Fault).
- The Modbus state parameter is changed to indicate a fault condition that will be reported to a unit controller requesting this information.
- The diagnostic LEDs display the various fault conditions as shown in [Figure 3](#).

**Figure 3: Fault Descriptions**

LED Display	LED Display Interpretation	Description
FLT CF6	Sensor Configuration Error	The sensors identified during the discovery process do not match the expected configuration.
F01 LOC	Fault Sensor #1 Loss of Communications	A Fault condition exists due to a loss of Modbus communications with sensor #1.
F0N LOC	Fault Sensor #N Loss of Communications	A Fault condition exists due to a loss of Modbus communications with sensor #N.  N=relative sensor number (1-8)
F01 FLT	Fault Sensor #1 Self-Test Error	A Fault condition exists based on a sensor #1 failure during the self-test process.
F0N FLT	Fault Sensor #N Self-Test Error	A Fault condition exists based on a sensor #N failure during the self-test process.  N=relative sensor number (1-8)

**Table 6: MT6210 A2L Control Board State Matrix**

MT6210 A2L Control Board State Matrix		Board States				
		No Power	Start-up	Run	Fault	Alarm
Outputs	Alarm Relay	Open	Closed	Closed	Closed	Open
	Alarm Digital Output	Low	High	High	High	Low
	Fault Digital Output	Low	High	High	Low	High
	Customer Connection Relay	Open	Open	Open	Open	Closed

If a leak is detected, the relay for the supply air fan will energize or de-energize depending on conditions shown in this table.

Shaded cells represent de-energized relays (Off).  
Non-shaded cells represent energized relays (On).

# Display Modes

## Accessing Display Modes

The MODE button allows the user to access sensor/network information and enter a manual test mode while the control is running. The MODE button is located as shown in [Figure 4](#).

Figure 4: Mode Button Location

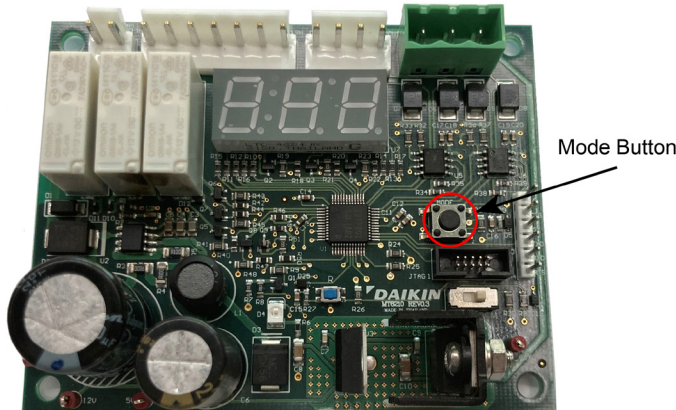

When the Mode button is pressed for the prescribed timing, the LED display will enter the associated mode as shown in [Table 7](#).

Table 7: Display Modes

Mode Button Press Duration (t)	Display Mode
t < 2 seconds	Error History
2 < t < 5 seconds	Sensor Status
5 < t < 10 seconds	Manual Test Mode
10 < t < 15 seconds	GID Display Mode

**NOTE:** Display Modes will not be available during an active alarm event.

## Error History Mode

Pressing and releasing the MODE button for less than 2 seconds places the display into Error History Mode. During this time interval, the display shows HST.

### Function

The last ten (10) errors will be displayed sequentially beginning with the most recent.

### Display

1. Each entry will be preceded by the order number in the history buffer.
2. Alarms are displayed as a single entry indicating the sensor that exceeded the %LFL threshold.

Table 8: Display Example

LED Display	LED Display Interpretation
1	1st History Record
A02	Alarm on Sensor 2

3. Faults are displayed as a double entry indicating the sensor involved and the type of fault incurred.

Table 9: Display Example

LED Display	LED Display Interpretation
2	2nd History Record
F01 FLT	Self-test failure on Sensor 1
3	3rd History Record
F04 LOC	Communication error on Sensor 4

4. The display returns to normal operation after the last data is shown.

## Sensor Status Mode

Pressing and releasing the MODE button for more than 2 seconds but less than 5 seconds places the display into Sensor Status Mode. During this time interval, the display shows STS.

### Function

The user can scroll through status information for each sensor in the system, including the current %LFL and any active Fault states. Alarm states are indicated by the %LFL level exceeding the alarm threshold (typically 15%).

### Display

1. The user scrolls through the information by subsequent button presses after entering the Sensor Status Mode.
2. The display shows the sensor number, %LFL, and active fault (if any).
3. The display will scroll through all eight sensors (1-8) and show LOC for any sensors not communicating or not installed.
4. In the case of a system with four sensors, where three sensors are operating normally and sensor 2 has an internal fault, the display responds as shown in [Table 10 on page 11](#).

Table 10: Display Example

Sensor State	Action	LED Display	LED Display Interpretation
Normal operation	Initial Display	S01	Sensor #1
	Button Press	024	Sensor #1 LFL=02.4%
There is an active fault condition	Button Press	S02	Sensor #2
	Button Press	FLT	Sensor #2 Self-Test Failure
Normal operation	Button Press	S03	Sensor #3
	Button Press	019	Sensor #3 LFL=01.9%
Normal operation	Button Press	S04	Sensor #4
	Button Press	021	Sensor #4 LFL=2.1%
Not Installed	Button Press	S05	Sensor #5
	Button Press	LOC	Sensor #5 Loss of Com
Not Installed	Button Press	S06	Sensor #6
	Button Press	LOC	Sensor #6 Loss of Com
Not Installed	Button Press	S07	Sensor #7
	Button Press	LOC	Sensor #7 Loss of Com
Not Installed	Button Press	S08	Sensor #8
	Button Press	LOC	Sensor #8 Loss of Com

5. The display returns to normal operation upon the button press after the last data is shown.

## Manual Test Mode

 <b>WARNING</b>
Placing the MT6210 into Manual Test Mode may initiate a system mitigation response, including energizing fans, disabling compressors, or other unit specific operational responses. Ensure unit is prepared for operation and safety precautions are followed prior to entering Manual Test Mode.

Pressing and releasing the MODE button for more than 5 seconds but less than 10 seconds places the display into Manual Test Mode. During this time interval, the display shows TST.

### Function

The user can place the MT6210 into an alarm state to test system response in a field installation. The test mode will last for five (5) minutes, then return to normal operation.

### Display

The display indicates the test mode is active and a countdown timer showing the time remaining (seconds) in the Manual Test Mode, as shown in Table 11.

Table 11: Display Example

LED Display	LED Display Interpretation
A99	Field Test Mode Indication
TST	Test Indication
TST	Test Indication
300	5 Minute Countdown Timer

## GID Display Mode

Pressing and releasing the MODE button for more than 10 seconds but less than 15 seconds places the display into GID Display Mode. During this time interval, the display shows GID.

### Function

The user can place the MT6210 into GID Display Mode to view the current values for all active parameters in the Global Identifiers List. This mode is only available when the control is in the RUN state (no faults/alarms).

### Display

The display automatically scrolls through all active GIDs sequentially. The following rules apply:

1. The display will show the GID number (sequentially beginning with GID #1) followed by the current value for that GID as shown in [Table 12 on page 13](#).
2. Each sensor address is displayed, whether the sensor is installed or not.
3. For each valid sensor (address ≠ "0"), the control displays the sensor information, including:
  - Sensor address
  - LFL level
  - Sensor state
  - Sensor faults
  - Sensor temperature
  - Sensor humidity
  - Sensor pressure (future feature, will show invalid)
4. If a sensor is not communicating at the time of display, the sensor address GID will show a zero (0) and the details of that sensor will not be shown.
5. If a GID value is greater than "999" or not valid, the LED will be blank during that GID value display time.

**Table 12: GID Table**

GID #	GID Name	Minimum Value	Maximum Value	Default Value	Description
1	Number of Sensors	1	8	2	Number of sensors configured.
2	LFL Fault Threshold	1	10000	500	LFL FAULT Threshold setting (%LFLx10)
3	LFL ALARM Threshold	1	1000	150	LFL ALARM Threshold setting (%LFLx10)
4	USB Baud Rate	19200	115200	115200	Baud Rate used with an external terminal
5	MODbus Client Baud	19200	38400	38400	Baud Rate used with the sensors
6	MODbus Server Baud	9600	115200	19200	Baud Rate used with an external controller
7	Test Mitigation Time	10	300	300	Manual Test time (seconds)
8	Sensor Warm Up Time	5	180	30	Sensor warm-up time delay (seconds)
9	Mitigation Time	120	1200	300	Post alarm mitigation time - LFL<15% (seconds)
10	Num of Sensors Online	1	8	1	Number of sensors discovered in network
11	A2L State	0	5	0	A2L System State (See Note 1)
12	Last Fault	0	2	0	Recent Fault (0 = No fault, 1=CFG, 2=LOC/FLT)
13	Modbus Server Address	1	10	9	A2L Modbus Address - Modbus Server Network
14	Sensor Addr Min	45	50	48	Minimum sensor address (Maximum=Min+7)
15	EETbl Save Now	0	1	0	Command to save data (1=Save Execute)
16	System Test	0	1	0	System Test Request (1= Test initiates)
17	Display LFL	0	1	0	Display LFL Levels externally (1=Start display)
18	EETbl LoadDefaults	0	1	0	Load Defaults values (1=Load)
19	EETbl Rev	1	1	1	Table version (Factory use only)
20	Sensor 1 Address	GID14	GID14+7	0	Sensor 1 Address
21	Sensor 1 Level	0	1000	0	Sensor 1 LFL value (%LFLx10)
22	Sensor 1 State	1	5	0	Sensor 1 state (See Note 2)
23	Sensor 1 Faults	0	65535	0	Sensor 1 internal fault
24	Sensor 1 Temperature	-400	940	0	Sensor 1 temperature (°Cx10)
25	Sensor 1 Humidity	0	1000	0	Sensor 1 humidity (RHx10)
26	Sensor 1 Pressure	0	4000	0	Sensor 1 pressure (future use)
27	Sensor 2 Address	GID14	GID14+7	0	Sensor 2 Address
28	Sensor 2 Level	0	1000	0	Sensor 2 LFL value (%LFLx10)
29	Sensor 2 State	1	5	0	Sensor 2 state (See Note 2)
30	Sensor 2 Faults	0	65535	0	Sensor 2 internal fault
31	Sensor 2 Temperature	-400	940	0	Sensor 2 temperature (°Cx10)
32	Sensor 2 Humidity	0	1000	0	Sensor 2 humidity (RHx10)
33	Sensor 2 Pressure	0	4000	0	Sensor 2 pressure (future use)
34	Sensor 3 Address	GID14	GID14+7	0	Sensor 3 Address
35	Sensor 3 Level	0	1000	0	Sensor 3 LFL value (%LFLx10)
36	Sensor 3 State	1	5	0	Sensor 3 state (See Note 2)
37	Sensor 3 Faults	0	65535	0	Sensor 3 internal fault
38	Sensor 3 Temperature	-400	940	0	Sensor 3 temperature (°Cx10)
39	Sensor 3 Humidity	0	1000	0	Sensor 3 humidity (RHx10)
40	Sensor 3 Pressure	0	4000	0	Sensor 3 pressure (future use)
41	Sensor 4 Address	GID14	GID14+7	0	Sensor 4 Address
42	Sensor 4 Level	0	1000	0	Sensor 4 LFL value (%LFLx10)

GID #	GID Name	Minimum Value	Maximum Value	Default Value	Description
43	Sensor 4 State	1	5	0	Sensor 4 state (See Note 2)
44	Sensor 4 Faults	0	65535	0	Sensor 4 internal fault
45	Sensor 4 Temperature	-400	940	0	Sensor 4 temperature (°Cx10)
46	Sensor 4 Humidity	0	1000	0	Sensor 4 humidity (RHx10)
47	Sensor 4 Pressure	0	4000	0	Sensor 4 pressure (future use)
48	Sensor 5 Address	GID14	GID14+7	0	Sensor 5 Address
49	Sensor 5 Level	0	1000	0	Sensor 5 LFL value (%LFLx10)
50	Sensor 5 State	1	5	0	Sensor 5 state (See Note 2)
51	Sensor 5 Faults	0	65535	0	Sensor 5 internal fault
52	Sensor 5 Temperature	-400	940	0	Sensor 5 temperature (°Cx10)
53	Sensor 5 Humidity	0	1000	0	Sensor 5 humidity (RHx10)
54	Sensor 5 Pressure	0	4000	0	Sensor 5 pressure (future use)
55	Sensor 6 Address	GID14	GID14+7	0	Sensor 6 Address
56	Sensor 6 Level	0	1000	0	Sensor 6 LFL value (%LFLx10)
57	Sensor 6 State	1	5	0	Sensor 6 state (See Note 2)
58	Sensor 6 Faults	0	65535	0	Sensor 6 internal fault
59	Sensor 6 Temperature	-400	940	0	Sensor 6 temperature (°Cx10)
60	Sensor 6 Humidity	0	1000	0	Sensor 6 humidity (RHx10)
61	Sensor 6 Pressure	0	4000	0	Sensor 6 pressure (future use)
62	Sensor 7 Address	GID14	GID14+7	0	Sensor 7 Address
63	Sensor 7 Level	0	1000	0	Sensor 7 LFL value (%LFLx10)
64	Sensor 7 State	1	5	0	Sensor 7 state (See Note 2)
65	Sensor 7 Faults	0	65535	0	Sensor 7 internal fault
66	Sensor 7 Temperature	-400	940	0	Sensor 7 temperature (°Cx10)
67	Sensor 7 Humidity	0	1000	0	Sensor 7 humidity (RHx10)
68	Sensor 7 Pressure	0	4000	0	Sensor 7 pressure (future use)
69	Sensor 8 Address	GID14	GID14+7	0	Sensor 8 Address
70	Sensor 8 Level	0	1000	0	Sensor 8 LFL value (%LFLx10)
71	Sensor 8 State	1	5	0	Sensor 8 state (See Note 2)
72	Sensor 8 Faults	0	65535	0	Sensor 8 internal fault - Varies by sensor mfg
73	Sensor 8 Temperature	-400	940	0	Sensor 8 temperature (°Cx10)
74	Sensor 8 Humidity	0	1000	0	Sensor 8 humidity (RHx10)
75	Sensor 8 Pressure	0	4000	0	Sensor 8 pressure (future use)
76	DF Saving Time	15	120	15	Data Flash saving interval time (minutes)
77	Nominated Sensor Addr	GID14	GID14+7	55	Sensor address to be reset to the default value
78	Sensor Reset Command	0	1	0	Sensor address reset command (1=Reset)
79	Sensor Reset Result	0	1	0	Result of the sensor reset (0=Success)

**NOTE:** A2L System State (0=Start-Up, 1=Run, 2=Fault, 3=Alarm, 4=Post Alarm, 5=Test)  
 Sensor state (1=Start-up, 2=Run, 3=Reserved, 4=Fault, 5=Self-test)

# Replacing Faulty Sensors

 **WARNING**

Field replacement sensors must be Daikin Applied approved service parts. The use of non-certified parts can result in property damage, personal injury, or death.

The refrigerant sensors are designed to be maintenance-free for the life of the equipment, but it is always a possibility for failures to occur in the field. In the unlikely event that a sensor does fail, replacing the failed sensor can be easily accomplished with an new, unused sensor acquired from a certified Daikin Applied service parts supplier.

## Sensor Failure Indicators

The need to replace a refrigerant sensor in the field can be indicated in one of three ways:

1. **Loss of Communication (LOC)**  
The sensor's capability to communicate to the MT6210 control has been compromised by an internal fault in the sensor. It is important to rule out other causes of the communication failure that might exist outside the sensor itself, such as loose connections or broken wires.
2. **Sensor Self-Test Failure (FLT)**  
The sensor failed its internal self-test and reported this failure to the MT6210. The self-test periodically checks that the sensor's internal functions and tolerances are within normal operating parameters and reports the status of these tests continuously.
3. **Configuration Error (CFG)**  
A configuration error indicates a mismatch between the expected sensor configuration and what the control is seeing on the sensor network. This is an unlikely condition where the number or addressing of the sensors is incorrect, and there are distinct steps to diagnose the exact cause of this error.

## Sensor Network Verification

When a sensor failure is indicated, the current state of sensor network should be verified following these steps:

1. Remove the 24 VAC power from the MT6210 control. This can be easily accomplished by shutting down the main power to the unit. The MT6210 typically provides power to all the refrigerant sensors in the system, so removing power from the MT6210 also powers down the sensor network.
2. If an auxiliary 5 VDC power supply is used to power the refrigerant sensors separate from the MT6210 internal power supply, ensure this is also powered down.
3. Leave the controller/network un-powered for 30 seconds.
4. Re-apply power to the controller/network.
5. Observe the MT6210 LED display for the network summary information. This information is displayed after the 30 second warm-up period (St-UP). Record which sensors are present (S0x=1) and which sensors are not (S0x=0).

6. Continue to observe the MT6210 display for re-occurrence of the previous fault.

## Identifying Faulty Sensor

Confirmation of the sensor issue for each failure indication is as follows:

1. The sensor indicating the LOC Fault shows as a missing sensor in the power-up network summary. For example, if the system fault was S02 LOC and the network summary shows S02=0, then the failure is confirmed.
2. The sensor indicating the FLT Fault shows as an active sensor in the power-up network summary, S0x=1, and the S0x FLT fault re-appears after start-up, the failure is confirmed.
3. In the case of the CFG FLT fault, the indication will be a mis-addressed sensor in the network or more sensors discovered than the number of sensors expected. This will be indicated during the power-up network summary and may require factory assistance to resolve.

## Installing Single Replacement Sensors

Once the failed sensor is verified, the sensor location must be ascertained and access to the sensor achieved. Once accessed, replace the sensor as follows:

1. Remove power the MT6210 control and auxiliary 5 VDC power supply (if used).
2. Disconnect the Modbus connection at the sensor pigtail (approximately 6" from the sensor body).
3. Remove the two screws securing the sensor to the sensor mounting bracket. Note the orientation of the sensor to the bracket.
4. Position a new, unused sensor on the bracket and secure with the mounting screws.
5. Connect the unit wiring harness to the new sensor.
6. Apply power to the controller/network.
7. Observe the MT6210 display and record the network status summary.

The MT6210 will identify the replacement sensor and re-address that sensor to its new location in the system. The system will indicate all sensors discovered and functioning, and the unit will resume normal operation.

**NOTE:** USE ONLY NEW, UNUSED SENSORS FOR FIELD REPLACEMENTS. If a previously installed sensor is used as the replacement sensor, the MT6210 will not identify that sensor as a replacement and the addressing routine may fail.

## Installing Multiple Replacement Sensors

When circumstances indicate the need to replace multiple sensors on the same unit in the field, it is recommended to replace all sensors to ensure the system regains its full robustness and functionality. Replacing system sensors requires the following actions:

1. Acquire the needed number of new, unused replacement sensors sufficient to replace all sensors. **Do not attempt to used previously installed sensors, as the MT6210 may not be able to properly address these sensors for replacement.**
2. Remove power from the controller/network.
3. Access all refrigerant sensors, disconnect them from the factory wiring harness, and remove the sensors from the sensor mounting brackets. Dispose of the old sensors properly.
4. Determine the location for sensor #1. This location will be clearly marked in the unit.
5. Install the new #1 sensor onto the sensor mounting bracket and connect the sensor to the factory wiring harness. **Ensure this is the only sensor connected to the network.**
6. Apply power to the controller/network, allow the controller to finish the start-up time, and observe the network status summary on the display.
7. Confirm the network summary indicates the successful discovery of sensor #1, S01=1.
8. Remove power from the controller/network and determine the location for sensor #2. This location will be clearly marked in the unit.
9. Install the new #2 sensor onto the sensor mounting bracket and connect the sensor to the factory wiring harness. **Ensure that sensor #1 is still connected to the network.**
10. Apply power to the controller/network, allow the controller to finish the start-up time and observe the network status summary on the display.
11. Confirm the network summary indicates the successful discovery of sensor #1, S01=1 and sensor #2, S02=1.
12. Continue this process sequentially for the remaining sensors, **ensuring that previously installed new sensors remain connected to the network** and confirming successful discovery after each subsequent sensor is installed.
13. Once all sensors have been installed and successfully addressed in the unit, normal operation can be resumed.



# MT6210 Firmware Updating Procedure

## Renesas Flash Programmer

The MT-6210 has the Renesas RA2L1 microcontroller which has an embedded bootloader to allow updating functional firmware over a serial interface. This bootloader interface uses serial channel 9 (SCI-9). The mode switch and mode button are used together to invoke the bootloader interface functionality.

1. Install the Renesas Flash Programmer  
The programmer can be downloaded from Renesas: <https://www.renesas.com/us/en/software-tool/renesas-flash-programmer-programming-gui>
2. Download the programmer to your computer, unzip and install.
3. Start the Renesas Flash Programmer:  
Start->Renesas Flash Programmer

Figure 5: Renesas Flash Programmer Screen

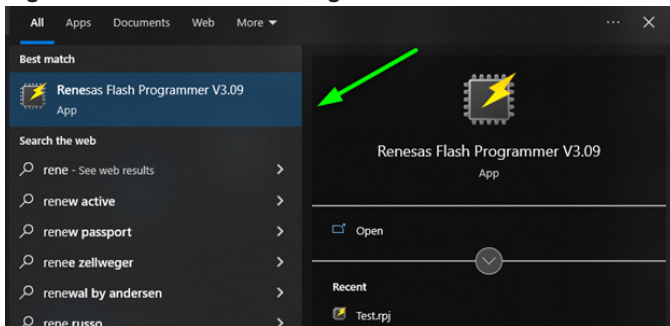

4. Select the Connect Settings  
Select the COM port and Speed settings shown.

Figure 6: Connect Settings Screen

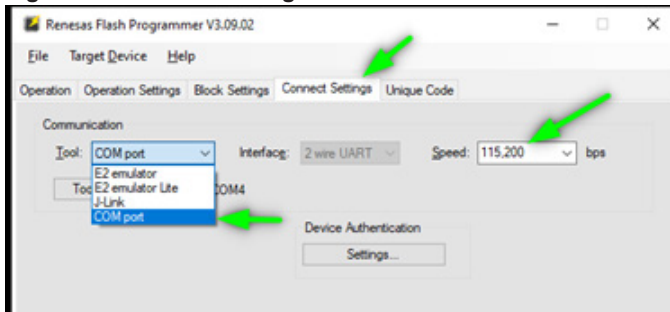

## Programming

Updating the firmware is accomplished with the following steps:

1. Connect the 6-pin serial cable with the FTDI to USB interface to the board.
2. Set the mode switch to "BOOT", then press the "RESET" button.

Figure 7: BOOT and RESET Buttons

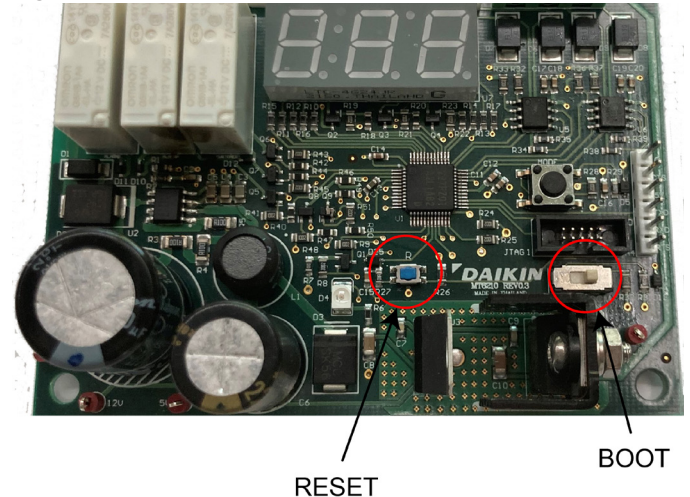

3. Initiate the programmer.  
Select the Operation tab of the Renesas Flash Programmer.  
Select the programming file, type "srec".  
Press the Start button.  
The programming sequence will commence.

Figure 8: Operation Tab

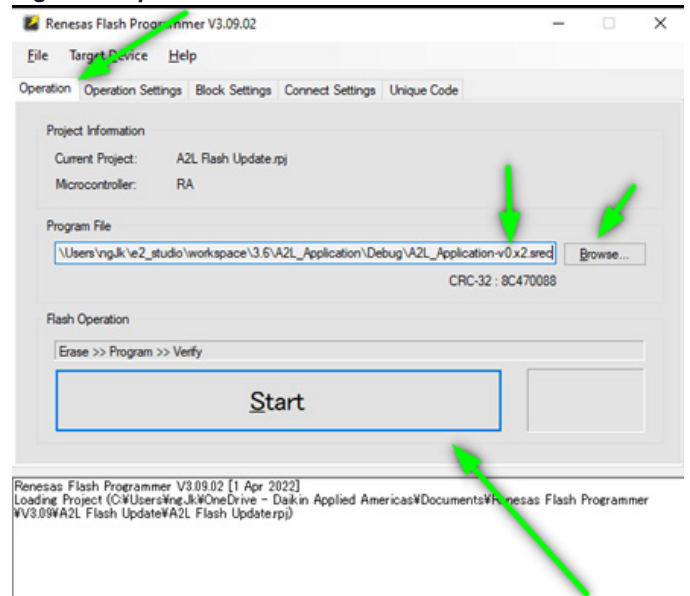

4. A successful programming operation will display as shown in Figure 9.

Figure 9: Operation Complete Example

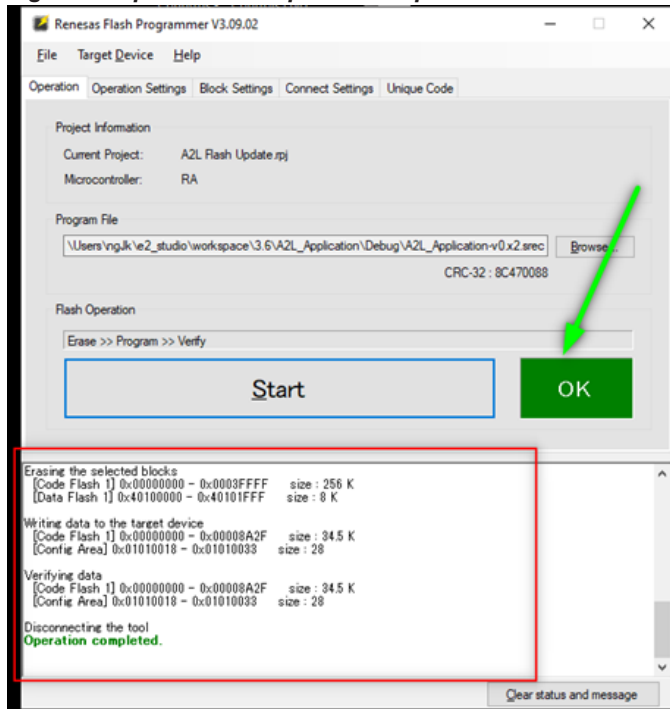

**NOTE:** If there is an “NG” for “no good” instead of OK, checks include if the board is in BOOT mode and it has been reset. The BCD display should be off.

### Verify and Return to Normal Operation

1. Put the switch back in “RUN” and press the “RESET” again to start the newly programmed firmware.
2. Close the Flash Programmer and start a console interface such as “PUTTY”.
3. Press enter and the newly revised firmware should respond with the proper version of firmware just loaded as shown in Figure 10.

Figure 10: Com4 - PuTTY Example

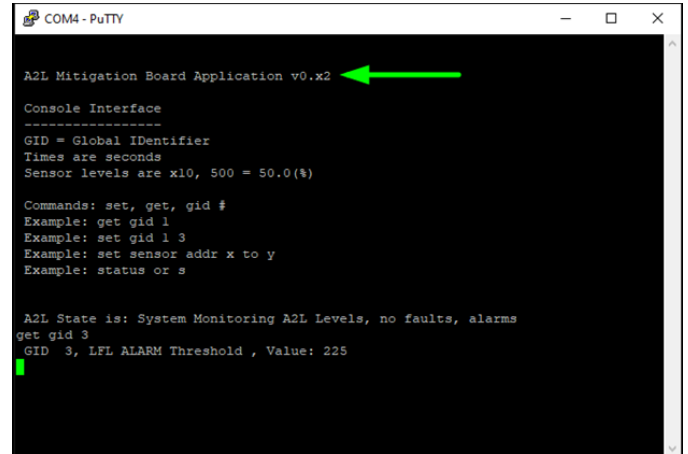

# Hardware Specifications

**Table 13: Hardware Specifications**

Subject	Description
Power Supply	Class II 24VAC 60HZ 6W Input Power $\pm 20\%$
Transformer Requirements	24VAC/75VA Class II
Operating Temperature	-40C to +70°C
Storage Temperature	-40°C to +85°C
Humidity	10% RH to 90% RH (Non-Condensing)
ESD Rating	+/- 8KV (Installed in Unit)
Power Surge Rating	Input Power Surge 2KV compliant to IEC 61000-4-5
Vibration Rating	50grms
Agency Compliance	Automatic Electrical Controls – Part 1: General Requirements [UL 60730-1: 2016 Ed.5+R:18Oct2021] Automatic Electrical Controls – Part 1: General Requirements [CAN/ CSE60730-1:2015 Ed.5+A1;A2]
Device Classification	Type 1 Class A Control Class 1 Appliance
Digital Inputs	"Mode Input" (User Activated SPST Toggle switch), "Boot" (User Activated Tactical push button, "Reset" (User Activated Tactile push button)
Digital Output	"Alarm" and "Fault" 0/5VDC (Active low) Binary Outputs
Dry Contacts	"Alarm" (2 series redundant N/C contacts) and "Customer" N/O contact 5A @ 250VAC; 3A @ 30VDC
Comm Ports	2 RS485 ports: 1 configured as "Modbus Client" (sensors). 1 configured as "Modbus Server" (unit controller)
Maximum Sensor Load (mA)	300 @ 5VDC



### ***Daikin Applied Training and Development***

Now that you have made an investment in modern, efficient Daikin Applied equipment, its care should be a high priority. For training information on all Daikin Applied HVAC products, please visit us at [www.DaikinApplied.com](http://www.DaikinApplied.com) and click on Training, or call 540-248-9646 and ask for the Training Department.

### ***Warranty***

All Daikin Applied equipment is sold pursuant to its standard terms and conditions of sale, including Limited Product Warranty. Consult your local Daikin Applied representative for warranty details. To find your local Daikin Applied representative, go to [www.DaikinApplied.com](http://www.DaikinApplied.com).

### ***Aftermarket Services***

To find your local parts office, visit [www.DaikinApplied.com](http://www.DaikinApplied.com) or call 800-37PARTS (800-377-2787). To find your local service office, visit [www.DaikinApplied.com](http://www.DaikinApplied.com) or call 800-432-1342.

This document contains the most current product information as of this printing. For the most up-to-date product information, please go to [www.DaikinApplied.com](http://www.DaikinApplied.com).

Products manufactured in an ISO Certified Facility.